

RANDALL FOLDING WALKRAMP

SPECIFICATION CHART

DEPLOYED SPECIFICATIONS

Nominal Ramp Length	Usable Width	Ramp Width	Ramp Height	Usable Siderail	Recommended Deck Height	Approximate Weight
14'	24 3/8"	25 7/8"	4 5/8"	2 1/16"	47" - 56"	154

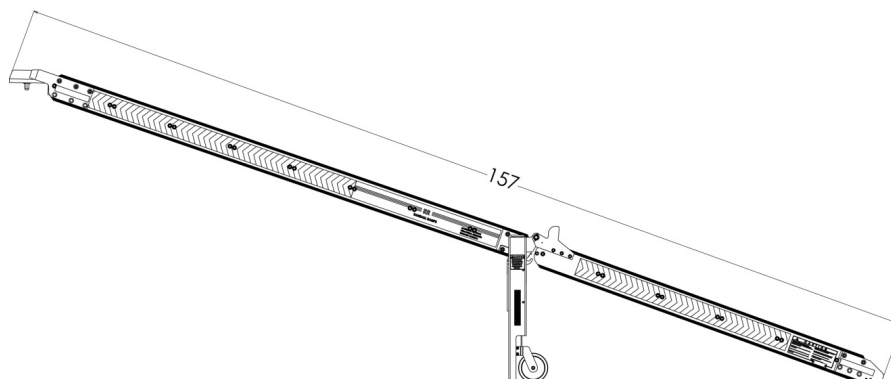

FOLDED SPECIFICATION

Folded Width	Folded Height	Folded Length
30 1/2"	9 5/8"	94 1/8"

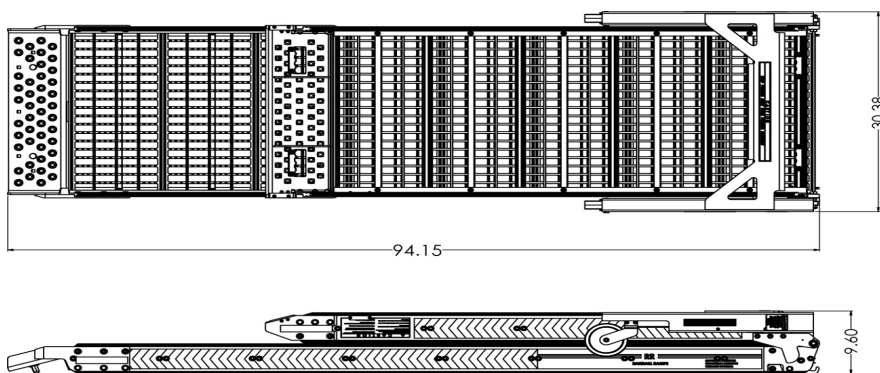

All ramps - 1,000 lb. load capacity

Testing of ramps was conducted between 15° and 20°

Load tests were conducted with a 500 lb. load and 225 lb. driver

WALKRAMPS » FOLDING WALKRAMP SPECIFICATIONS

ENCLOSURE (Deployed Specification)

Enclosure Length	Width & Height of Enclosure Body	Width & Height at Door	Approximate Weight
8'	31" x 10 ½"	32" x 12 ½"	196

Note: The distance of the bottom of the enclosure to the ground must be a minimum of 26 inches

