

Bustin Slide & Go Platform SG-200 Series Installation Instructions

Introduction

R•O•M Platforms are designed to be installed under a trailer or truck body. This platform can be installed on any manufacturer's trailer or straight body.

IMPORTANT: Read this manual completely before installing the platform. The platform, carrier and optional lift assist are heavy when they are packaged together and could cause serious injury if mishandled or improperly installed.

The installation of the platform is not difficult if you follow the procedures outlined in this manual. Any unauthorized changes to these procedures, changes to the parts and/or assemblies will automatically void your warranty.

If you have any questions call 800-827-3692.

Installation – Tools & Equipment (not included)

- 3/4" and 9/16" Sockets
- 3/4" and 9/16" wrenches
- Drill
- 9/16" drill bit
- Allen wrenches
- Tape measure

Additional Requirements (not included)

- 1/2" X 2" grade 8 hardware (Item B supplied)
- 1/2" x 1 1/2" grade 8 hardware (Item C supplied)
- Assistance in lifting and moving system into place

Unpacking

The platform and stairs have been palletized.

Remove steel strapping buy cutting bands.

Locate hardware bag.

INSTALLATION INSTRUCTIONS

1. Locate Slide and Go platform assembly
2. Pull release handle on the underside of the landing
3. Pull landing out of carrier approx. 4"
4. Remove stop bolt (Item A) on both sides of the frame
5. Pull release handle and remove landing from carrier
6. Drill 7/16" holes in the carrier that match up with the mounting locations on the trailer, must use the two holes in the front channel
7. Ensure there is a 1/4" of clearance between the top of the platform and bottom edge of the truck
8. Bolt carrier to trailer ribs with 1/2" grade 8 bolts (Item B) supplied (MINIMUM 3 BOLTS AT FRONT OF CARRIER, 2 AT REAR OF CARRIER)
9. Torque bolts to a minimum of 50 ft lbs
10. Installation of landing is the reverse of removal
11. Open and close the entire system to ensure proper clearances and installation

Stair Frame Installation

1. Locate stair frame
2. Line up holes on stair frame and slide and go platform
3. Use all (4) 1/2" bolt hardware (item C) supplied to attach the stair frame and slide and go platform
4. Torque bolts to a minimum of 50 ft. lbs.
5. Open and close the entire system to ensure proper clearances and installation.
6. Install the railing and handrails to ensure proper fit.
7. Your Slide and Go is now ready to use

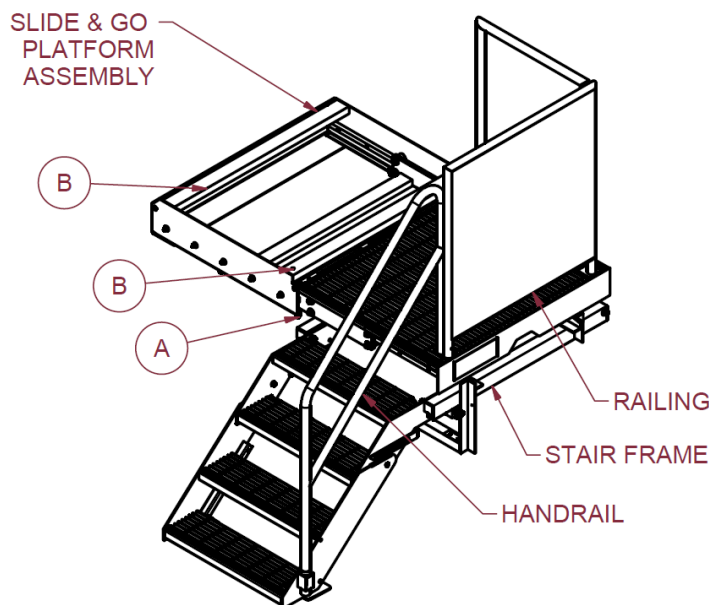

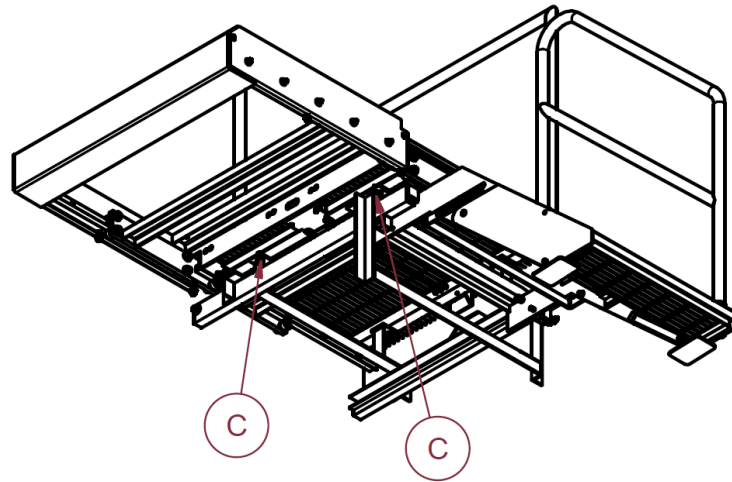

Preventative Maintenance and Usage

Your platform is now ready for use.

For proper care and platform maintenance reference:
FM-8.5-2024 – Preventative Maintenance and Usage Guidelines.

If you have any questions or problems, please contact your Customer Development Representative at 800-827-3692.

These drawings & the information contained herein are the confidential & proprietary intellectual property of R•O•M and should not be disclosed to any third party without the express prior written consent R•O•M.