

## Bustin Portable Ladder DE1102 & Carrier DB2502 Installation Instructions

### **DE1102 MOUNTING BRACKET WIDTH AND HEIGHT PLACEMENT**

The inside width from side plate to side plate of the brackets should be  $25\text{-}3/16" \pm 1/16"$ .

The height from the top edge of the support angle to the ground should be  $48\text{-}1/2" \pm 1/16"$ .

Four  $7/16$  holes should be placed in each bracket for mounting hardware.

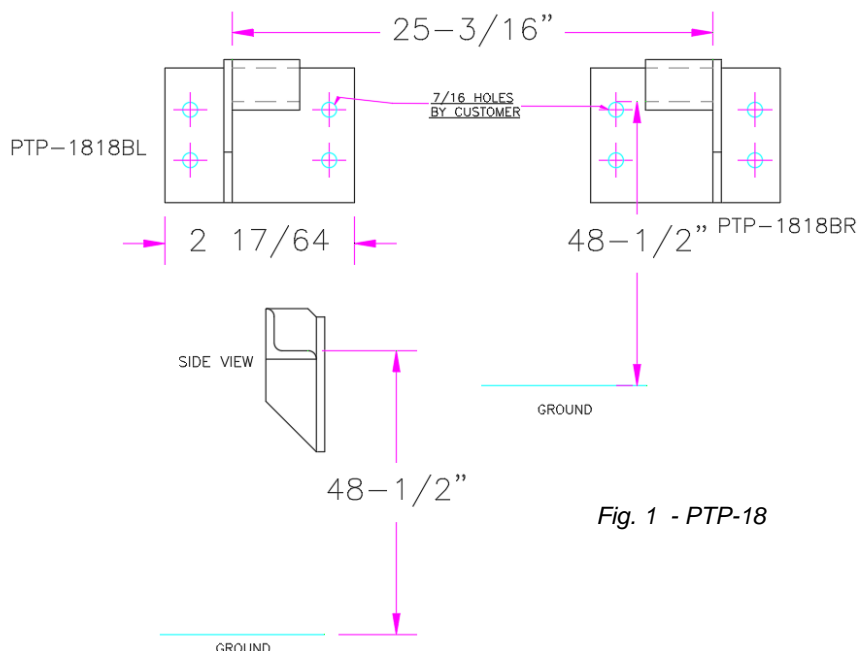

Fig. 1 - PTP-18

### **DB2502 MOUNTING INSTRUCTIONS**

Using the upper flanges of the carrier, mount to the desired structure using one of two methods:

*Option 1:*

Drill six evenly spaced holes centered on the flanges (3 per side)

*Option 2:*

Stitch weld inner and outer edges of flanges to structure in sufficient pattern and weld integrity.

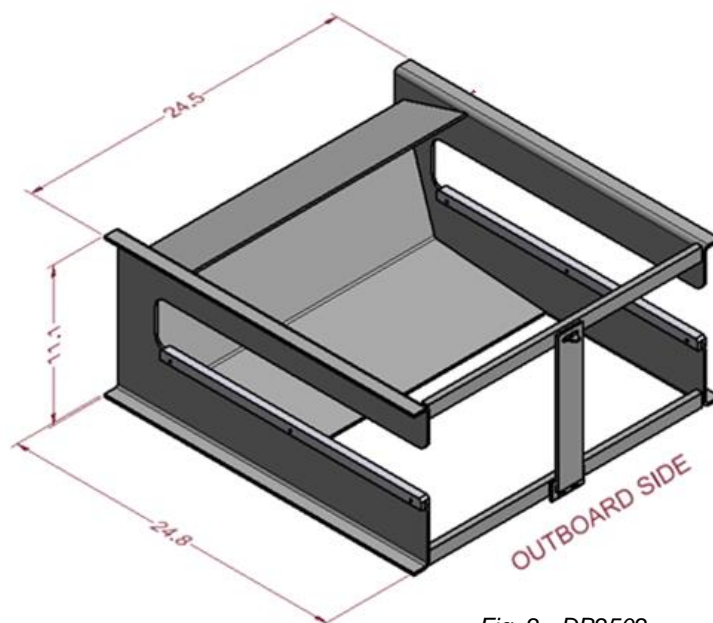

Fig. 2 - DB2502

If you have any questions or problems, please contact your Customer Development Rep. at 800-827-3692.

*These drawings & the information contained herein are the confidential & proprietary intellectual property of R•O•M and should not be disclosed to any third party without the express prior written consent R•O•M.*