

Bustin F600 Series Platform Preventative Maintenance & Usage Guidelines

This Preventative Maintenance and Usage guideline is to inform users that regular inspection of your platform must be completed every three months and it's advisable that drivers inspect the ladder daily before use. Using a damaged platform could result in bodily injury. Use only R•O•M replacement parts for repairs call 800-827-3692.

Inspect the pull pin assembly (1), make sure the pin locks the platform when in a deployed position, check the screws (2) holding the pull pin assembly to ensure they are tight. Ensure that the hardware (3) securing the slide blocks and support angles are properly tightened. Make sure when deploying the handrail, that the latch (4) locks the rail securely in place (on both sides) before the platform is used. Inspect flip plate hardware and hinge (5), make sure the hinge operates properly and is properly secured to the platform. Visually inspect the welds

Stressing and or excessive wear can be an indication of fatigue. Any components showing these signs should be replaced immediately. All labels shown in the diagram below must be legible. If not legible, be sure to replace as soon as possible: # 99 80 0063.

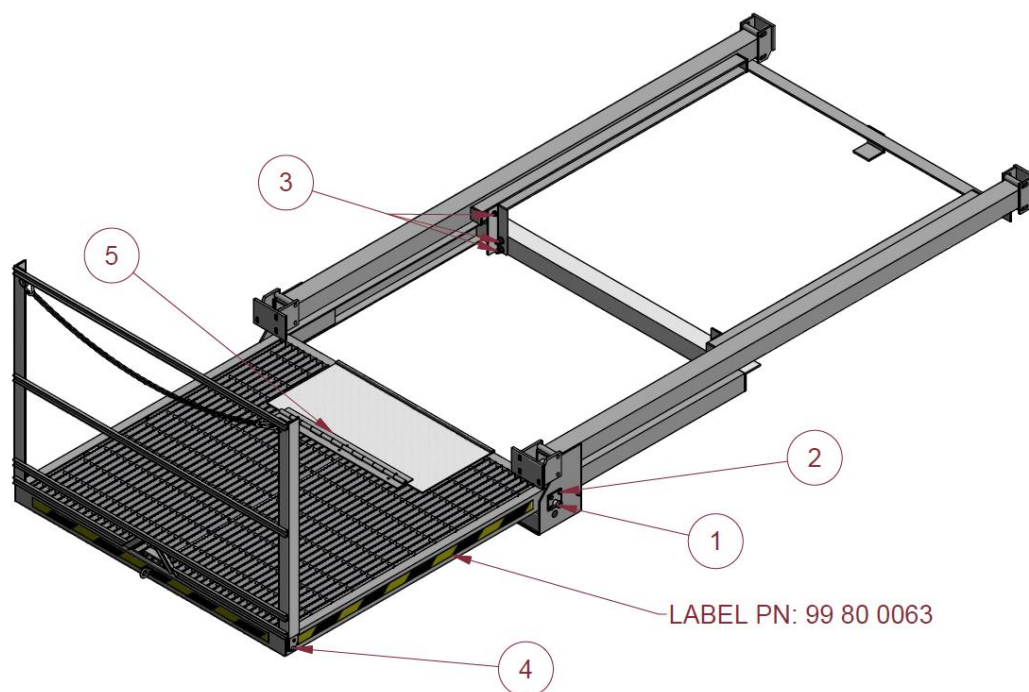

IMPORTANT: R•O•M also recommends that the platform be used on a level surface. Be sure to regularly inspect your platform for loose fasteners, and repair or replace damaged parts. Any parts that are damaged or loose can cause serious injury. Improper usage of the platform can cause damage and possibly void any remaining warranty. Please contact your Customer Development Representative at 800-827-3692.