

Bustin Slide Away Steps Parts Manual

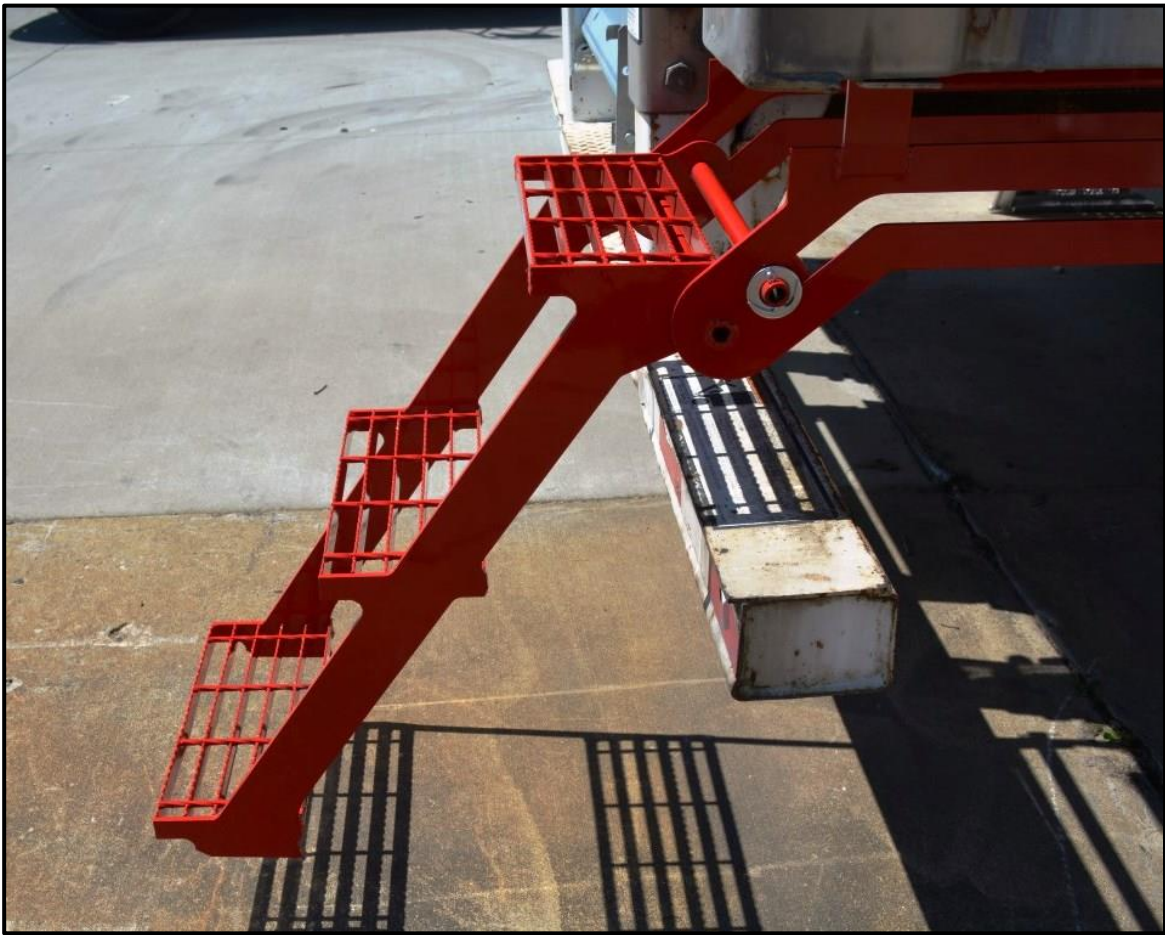
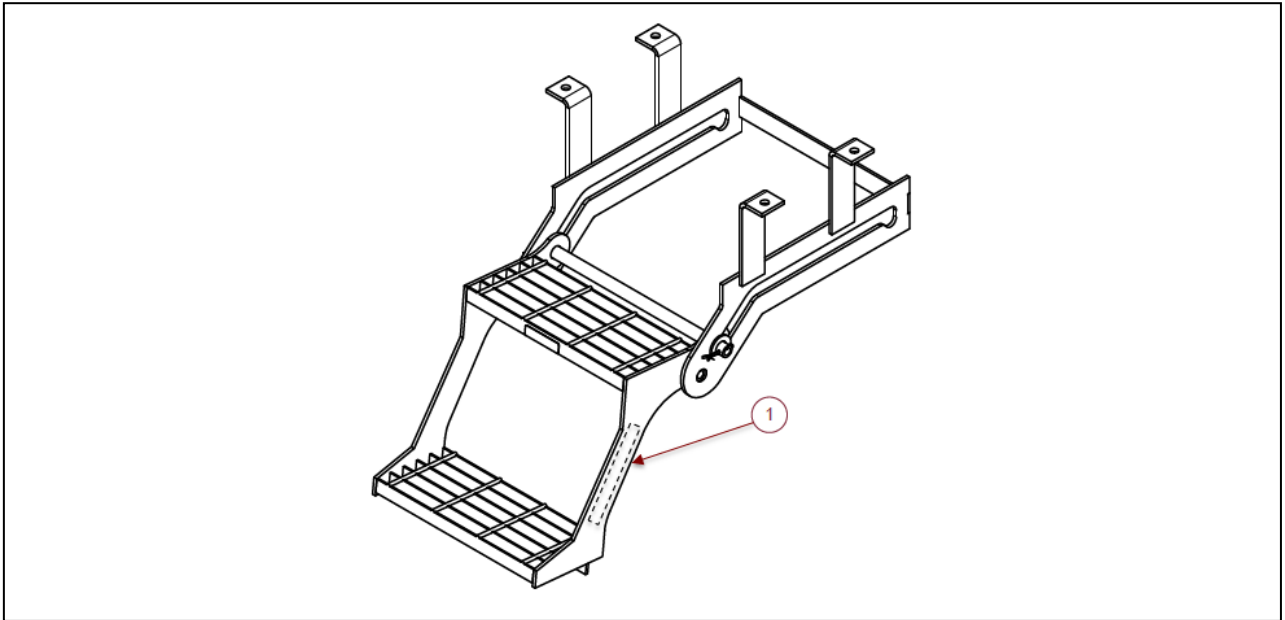

Table of Contents

Label, Slide Away Steps	3
Slide Bar Kit, Standard Step (14-1/2" wide)	4
Slide Bar Kit, Wide Step (26-1/2" wide)	5

Label



Label, Part No. LABEL005

Items #	Part Description	Quantity
1	WARNING LABEL - FALL HAZARD	1

SLIDE BAR KIT, STANDARD STEP (14-1/2" wide)

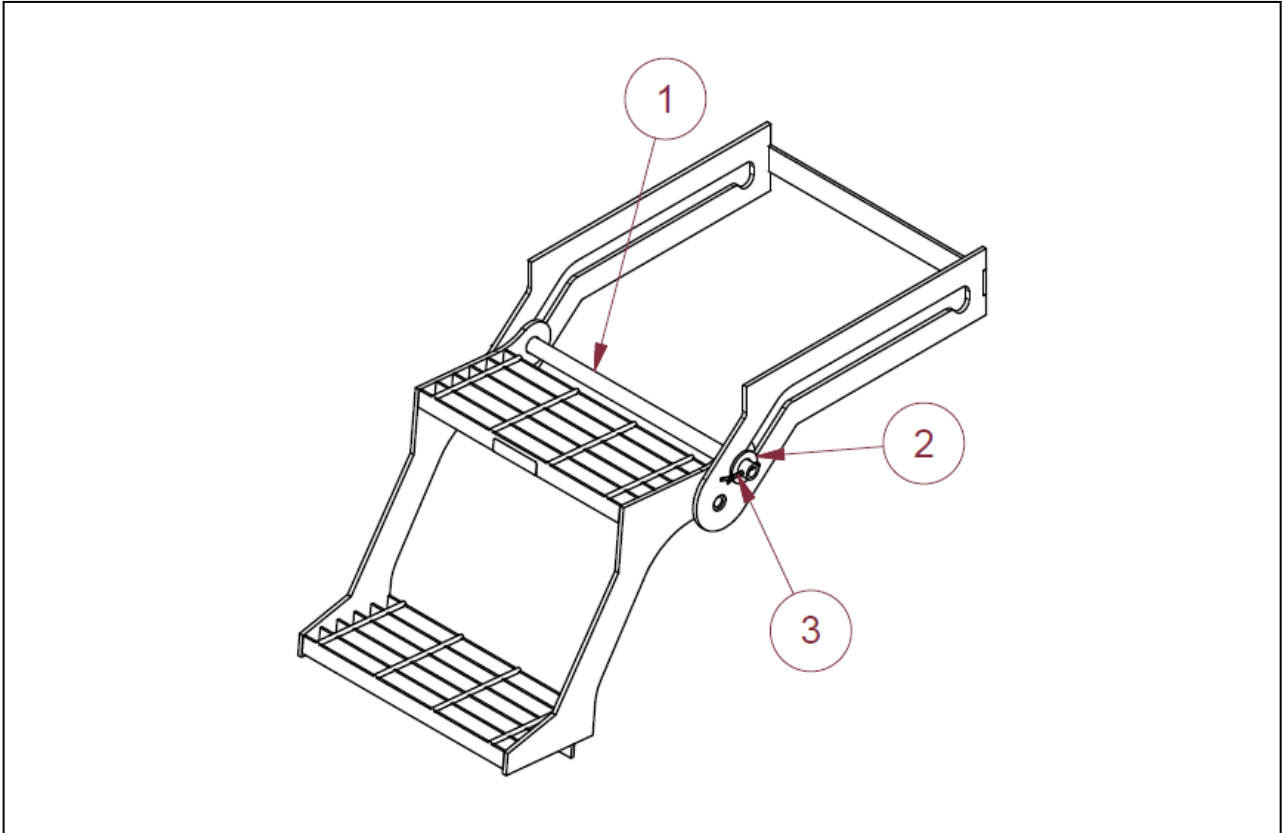

Slide Bar Kit, Standard, Part No. R04386

Items #	Part Description	Quantity
1	SLIDE PIPE, STANDARD, RED POWDER COAT FINISH	1
2	7/8" FLAT WASHER ZN PLATED	2
3	5/32" X 2" COTTER PIN	2
	** ITEM 1 - BLACK POWDER COAT AVAILABLE PER SPECIAL REQUEST	

* ITEM #1 SLIDE PIPE - BLACK POWDER COAT AVAILABLE PER SPECIAL REQUEST

SLIDE BAR KIT, WIDE STEP (26-1/2" wide)

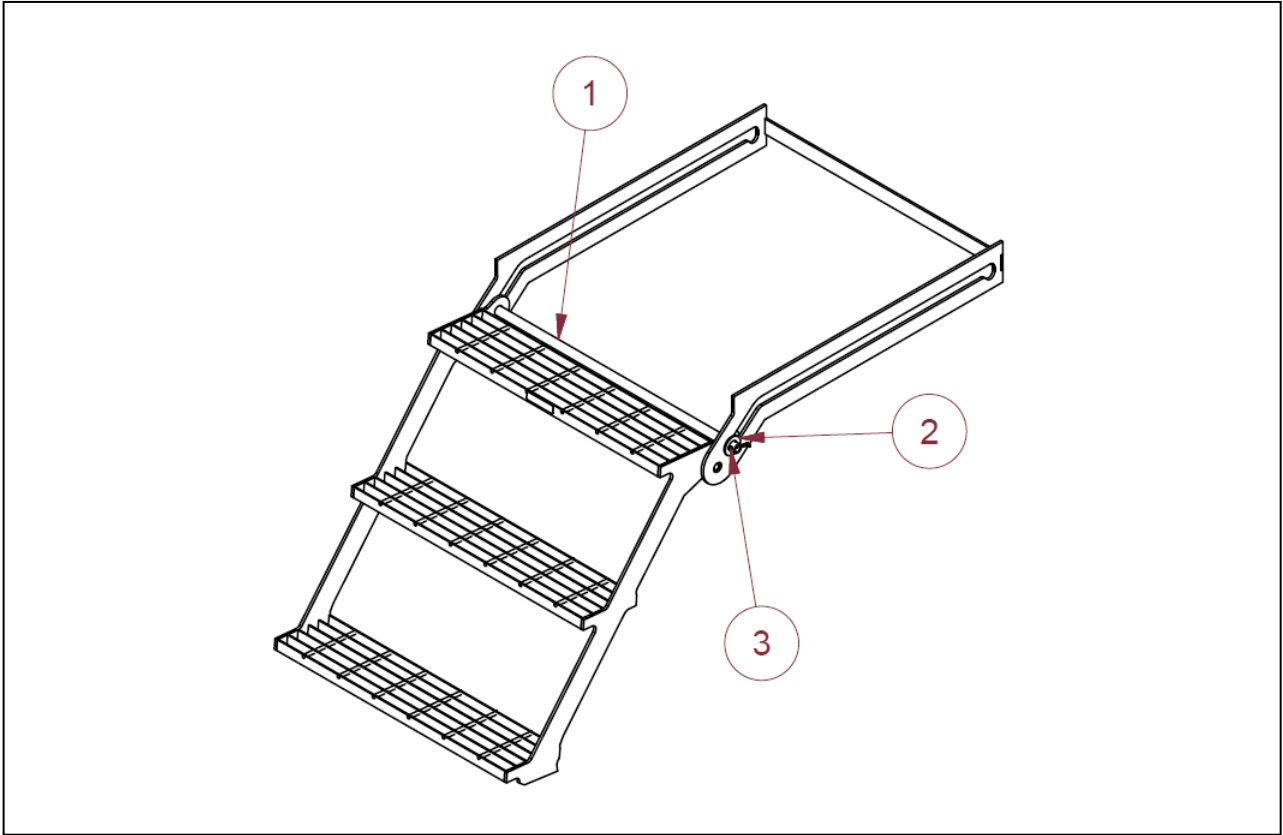

Slide Bar Kit, Wide, Part No. R04387

Items #	Part Description	Quantity
1	SLIDE PIPE, WIDE, RED POWDER COAT FINISH	1
2	7/8" FLAT WASHER ZN PLATED	2
3	5/32" X 2" COTTER PIN	2
	** ITEM 1 - BLACK POWDER COAT AVAILABLE PER SPECIAL REQUEST	

* ITEM #1 SLIDE PIPE - BLACK POWDER COAT AVAILABLE PER SPECIAL REQUEST